

# SPACE INVASION GAME

You've heard of the beer you drink at home — now ETI is doing its bit to clear the pubs with the Space Invasion game you play at home. Will the social life of England ever be the same?

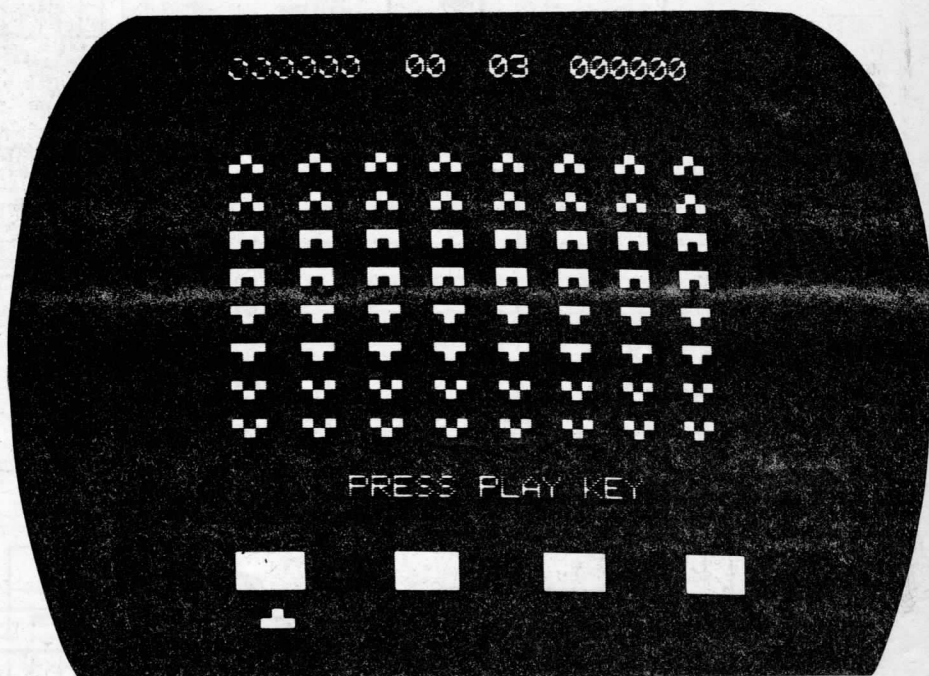

Hardware design by Paul Johnson. Software by Mike Rose.

One of the fastest growth industries of the last few years must be the production of video games. Only a couple of years ago we were pushing our five pence coins into the slot to play what was laughingly known as tennis (two oblong 'bats' and a blob that bounced all over the screen). Nowadays we can pilot starcruisers into the uncharted depths of space and zap the enemy with laser bolts, launch rescue missions to the Moon, and engage in dogfights with agile aliens who can fly rings round a cathode ray tube. Of course it costs more than fivepence too! Video games have probably led the field in showing the public that the microprocessor is capable of better things than frightening Clive Jenkins.

Life would be a lot better if you didn't have to keep feeding the coin slot to stay in practice, though, and as usual ETI comes to the rescue. Yes, for the first time anywhere we present a home-built version of the country's most popular pastime (all right, second most popular). Before you glance across to Buylines and decide we've got peculiar ideas about how to save you money, it should be pointed out that you get more than just a TV game. A TV game requires a microprocessor, some memory, a graphics generator, a keypad and a UHF output suitable for plugging into your television set. Amazingly enough these are also what you need for a home computer. Once you have the basic Space Invasion game, you can expand it at very little expense into just such a computer, designed by Tangerine Computer Systems.

## Playing the Game

The game follows a fairly standard format. Eight columns of eight saucers fly backwards and forwards across the TV screen and slowly descend while you take potshots at them from your laser base at the bottom of the screen. The base may be moved to left and right to aim at the enemy and to dodge the bombs they are dropping on you. If they hit you, your base is destroyed, but there are defences for you to hide under — these are gradually whittled away by the alien barrage. (Your laser bolts can cancel bombs as they fall.) Everything gets faster as the number of aliens decreases, and when they've all been wiped out, lo! another fleet appears.

Scoring is as follows: Top two rows — 50; Next two — 40; Next two — 30; Bottom two — 20. Every time you blast a saucer, its score is added to your total. Occasionally a huge saucer flies across the top of the screen; it doesn't drop bombs and hitting it scores 100 points. There are four numbers displayed at the top of the screen, and from left to right they are: score this game, number of saucers left on screen, number of bases you have left and highest score during this session. You start off with three bases and are awarded an extra one for every two thousand points, but you can't have more than four at once.

The switches are provided to select one of four levels of difficulty — these are set to either 0 V or 5 V and provide a binary input, 00 for easiest level (slow) and 11 for expert (very fast). →

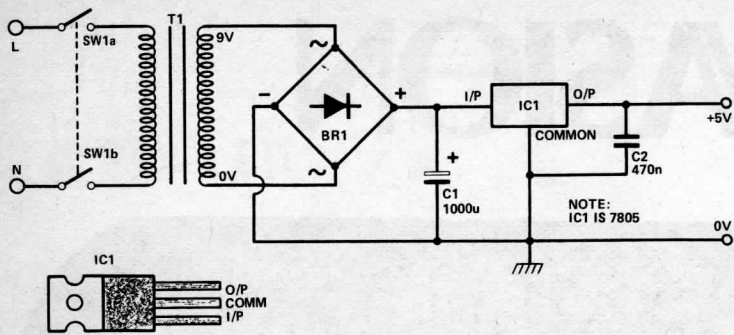
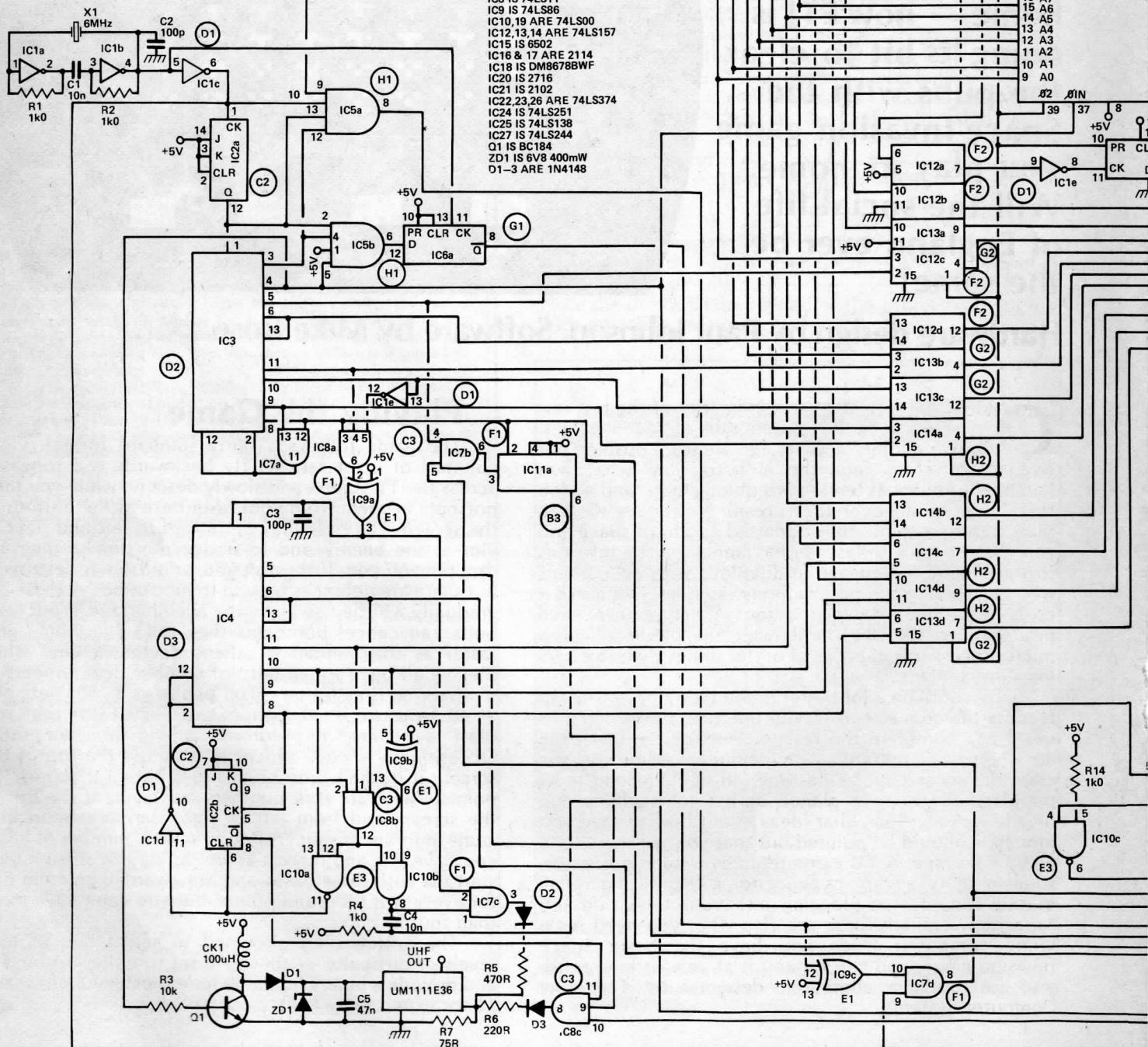
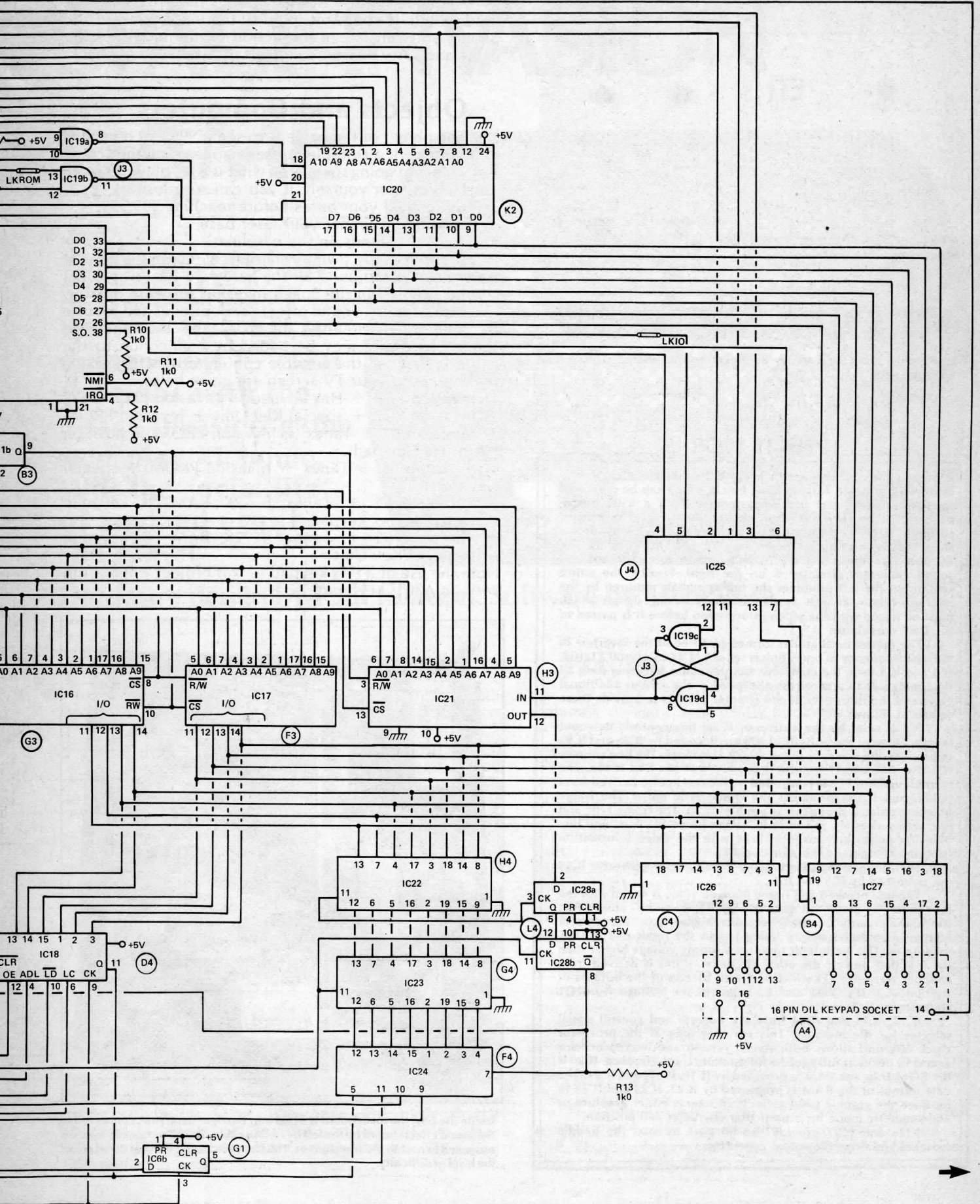

Fig.1. Circuit diagram of the main board and power supply.

- NOTE:  
 IC1 IS 74LS04  
 IC2 IS 74LS73  
 IC3,4 ARE 74LS393  
 IC5 IS 74LS21  
 IC6,11,28 ARE 74LS74  
 IC7 IS 74LS08  
 IC8 IS 74LS11  
 IC9 IS 74LS86  
 IC10,19 ARE 74LS00  
 IC12,13,14 ARE 74LS157  
 IC15 IS 6502  
 IC16 & 17 ARE 2114  
 IC18 IS DM8678BWF  
 IC20 IS 2716  
 IC21 IS 2102  
 IC22,23,26 ARE 74LS374  
 IC24 IS 74LS251  
 IC25 IS 74LS138  
 IC27 IS 74LS244  
 Q1 IS BC184  
 ZD1 IS 6V8 400mW  
 D1-3 ARE 1N4148







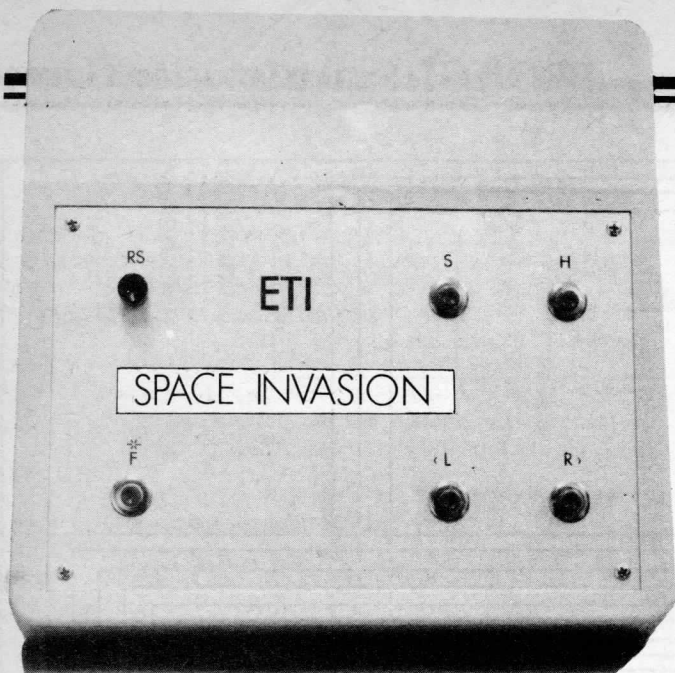

The face of the Space Invasion. The simple controls are reset, start (play), hold, fire, left and right.

## HOW IT WORKS

Although the circuit diagram looks hideously complex, it falls quite naturally into various basic blocks which can be examined separately. The heart of the system is IC15, a 6502 microprocessor. This can be seen at top centre of the circuit, surrounded by its memory and address decoding chips. Below these are the chips that generate the graphics for the display. The I/O port for connecting the main board to the keyboard and sound generator circuitry is on the right. Finally, the entire section on the left produces the timing signals required by the microprocessor, as well as all the synchronising signals which must be mixed with the video information before it is passed to the UHF modulator.

The master oscillator is formed by three of the inverters in IC1; the frequency of operation is set at 6 MHz by crystal X1. IC2, IC3 and IC4 form the complete counter chain for generating all the timing signals and refresh addresses — the various additional gates and flip-flops decode the counter outputs to provide these signals as follows.

IC3 is reset by the output of IC7a; this controls its count length. Three of the outputs of IC3 are decoded by IC8a and IC9a to produce the line sync pulse, which also clocks the line counter IC4. The line blanking pulse is produced at pin 6 of IC11a. The count length for IC4 is controlled by the reset pulse derived from IC10a, and IC10b produces the frame sync pulse. The frame blanking pulse is produced at pin 8 of IC2b. The frame sync and line sync pulses are mixed in IC7c; the frame blanking and line blanking pulses are mixed in IC8c with the video information from the character generator circuitry.

The timing signals for loading the character generator IC18 are produced by IC5 and IC6.

The line blanked and frame blanked video is mixed with the sync pulses by diode 'OR' gate D2, D3. R5, R6 and R7 ensure that the various parts of the composite signal have the correct relative amplitudes before being fed to the input of the UHF modulator. The modulator requires a supply voltage higher than the 5 V that powers the other circuitry — this is derived from chopper transistor Q1 which is driven by one of the outputs of counter IC3. D1, ZD1 and C5 regulate the voltage from Q1 collector to 6V8.

IC12, IC13 and IC14 form the address and control signal selector for the memory. This switches over at the processor clock rate and allows both screen refresh and microprocessor access to occur at full speed without mutual interference. IC20 is the ROM chip; the RAM is provided by IC16, IC17, and IC21. The data output of the RAM is processed by IC22, IC23 and IC24 to produce the graphic pixel cells. IC28 selects either graphics or alphanumeric mode for a particular character cell position.

IC26 and IC27 provide the I/O port to read the paddle switches and drive the sound generator.

A unique feature of this game is the provision of a hold switch. If you want to go to the loo, or answer the phone, you can freeze the action in the middle of the game and carry on where you left off when you get back.

## Objects and Computers

The object of the game is to score 999,999 points! If you manage it a suitable message appears on the screen but we're not going to tell you what it is — play the game and find out for yourself, if you can. You lose if:

- 1) You lose all your bases before reaching 999,999;
- 2) An invader touches your laser base;
- 3) An invader lands on the baseline.

If you already own a Microtan 65 computer than it isn't necessary to build all the hardware for this project — you simply run the Space Invasion software on your existing machine. Sound effects are optional and require the additional circuitry shown in the diagram. The special hardware may be added by connection to the cable socket. All the possible configurations for getting Invasion onto your TV screen are given below.

- 1) Invasion PCB + Hex keypad + Invasion PROM
- 2) Invasion PCB + special Key Unit + Invasion PROM
- 3) Microtan 65 + Tanex + Invasion PROM (in position E2) + Hex keypad
- 4) Microtan 65 + Tanex + Invasion PROM + special Key Unit
- 5) Microtan 65 + Tanex + 2K RAM + keyed-in software + Hex keypad
- 6) Microtan 65 + Tanex + 2K RAM + keyed-in software + Key Unit.

Note the use of a Hex keypad — this project will *not* run with an ASCII keyboard.

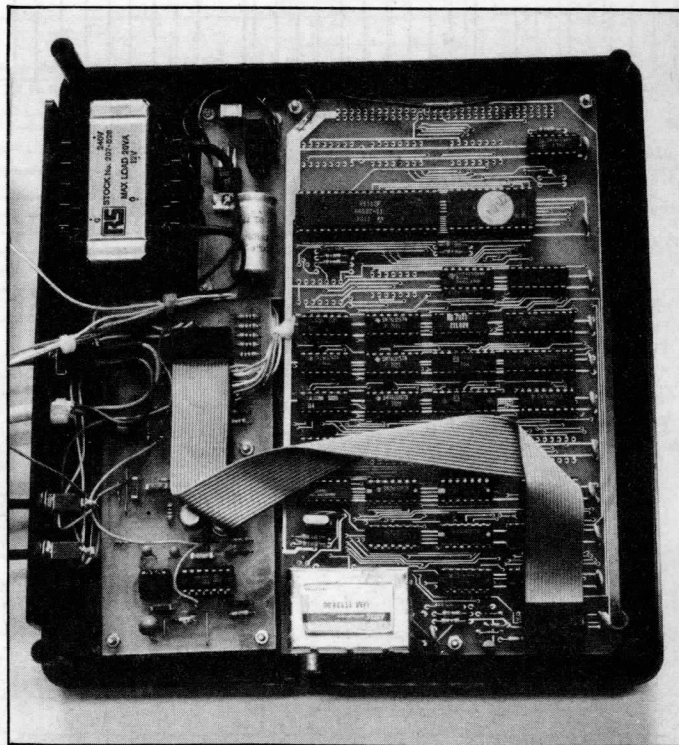

Inside the box, the main board is fitted into the right hand side, connected to the sound effects board on the left by ribbon cable. The power supply board is squeezed in next to the transformer. The two switches on the rear panel select the level of difficulty.



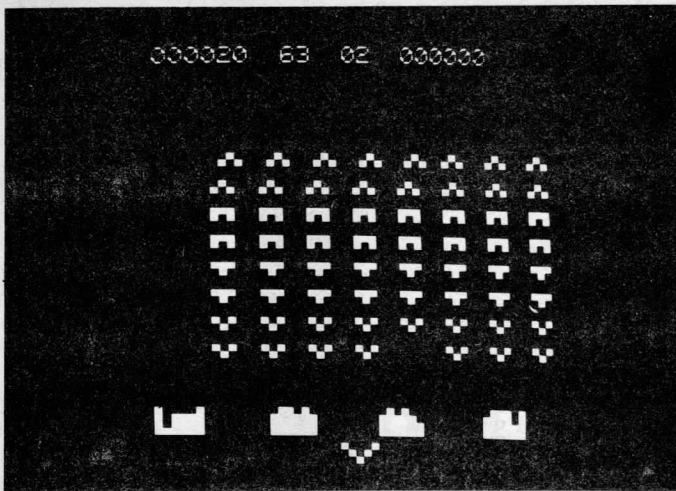

The screen display. This unfortunate space traveller has just been zapped by an alien.

## Construction

Tricky bit first. The main board is double-sided but it isn't necessary to solder components on both sides because the holes are plated through (sighs of relief). Fit the links and the discrete components first, being careful with the polarity where necessary, then solder all the IC sockets in the positions shown in the overlay diagram. You'll find there are more spaces for sockets than there are sockets but don't panic — this is to allow for later expansion into a computer as mentioned earlier. The UHF modulator is fixed to the PCB by soldering the case tags to the large pads provided — make sure it's the right way round. Now, double-checking both device type and orientation very carefully, plug the ICs into their sockets. Fit two lengths of wire for the power supply connections (these solder directly to the copper track) and the main board is complete. Check it again.

Well, there's still a long way to go. We have a score of 480 with 49 aliens still coming and no bases left. But we did better than the last astrogamerster. He only scored 20.

With a flying saucer zooming across the top of the screen, one alien has just launched a missile. Hit your left or right button quick! Or try to blow his (its) missile off the screen.

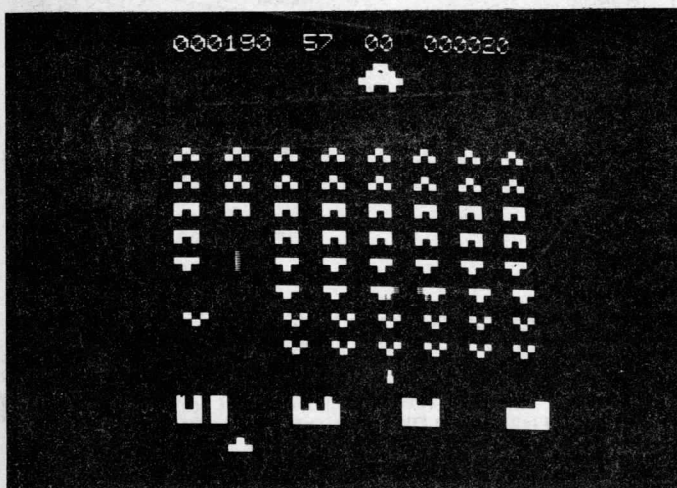

## Operating Differences

The UHF modulator for either version of the game is pre-tuned to Channel 36. Plug into the aerial socket, select a channel and adjust the tuning until the picture appears. If the game has been switched on without 'Reset' being operated, the screen will contain garbage.

If you are using the basic Invasion PCB, then operating the Reset switch brings the system into the 'ready-to-play' condition. If you are running the software on the Microtan 65, use Reset to gain access to TANBUG. The PROM is assembled to live at E800 (Hex), and the listing for the RAM version is assembled to live at 400 (Hex). So for the PROM version, typing GE800 brings the game to readiness by moving to the start address. With the software keyed into RAM, type G400.

If you are using the Hex keypad, the following keys are equivalent:

0 = PLAY

4 = BASE RIGHT

8 = BASE LEFT

C = FIRE

SHIFT = HOLD

Hitting any of the keys except HOLD removes hold.

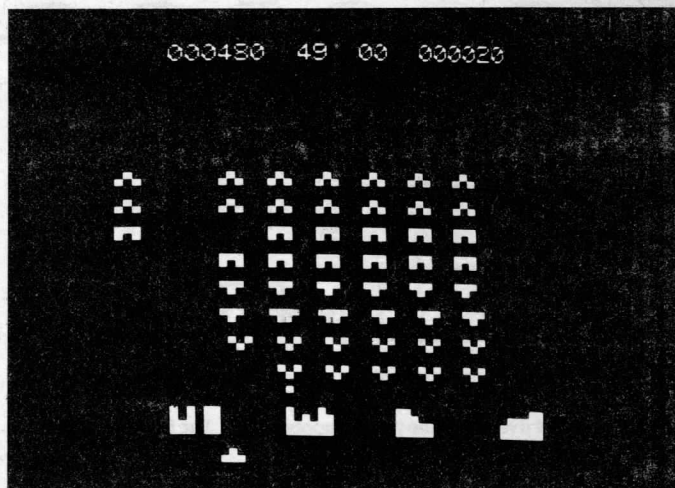

Now you can sit in front of your telly and make your living room a safe haven for the human race. For details of the modifications to produce a home computer, watch this space!

## BUYLINES

Tangerine Computers Ltd can supply the ETI Space Invasion project built for £99.85 all inclusive (or £80.85 in kit form). The sound generator and keypad section is available built for £20.55 all inclusive (or £15.38 in kit form).

If you want to shop around for your own components you can get the main Space Invasion PCB only for £21.15 all inclusive and the sound generator board for £5.60. The ROM is available for £17.75 all inclusive.

A case with internal PSU will be available from Tangerine soon. Contact them for the latest information on availability and price. Tangerine Computers Ltd, Forehill, Ely, Cambridgeshire.

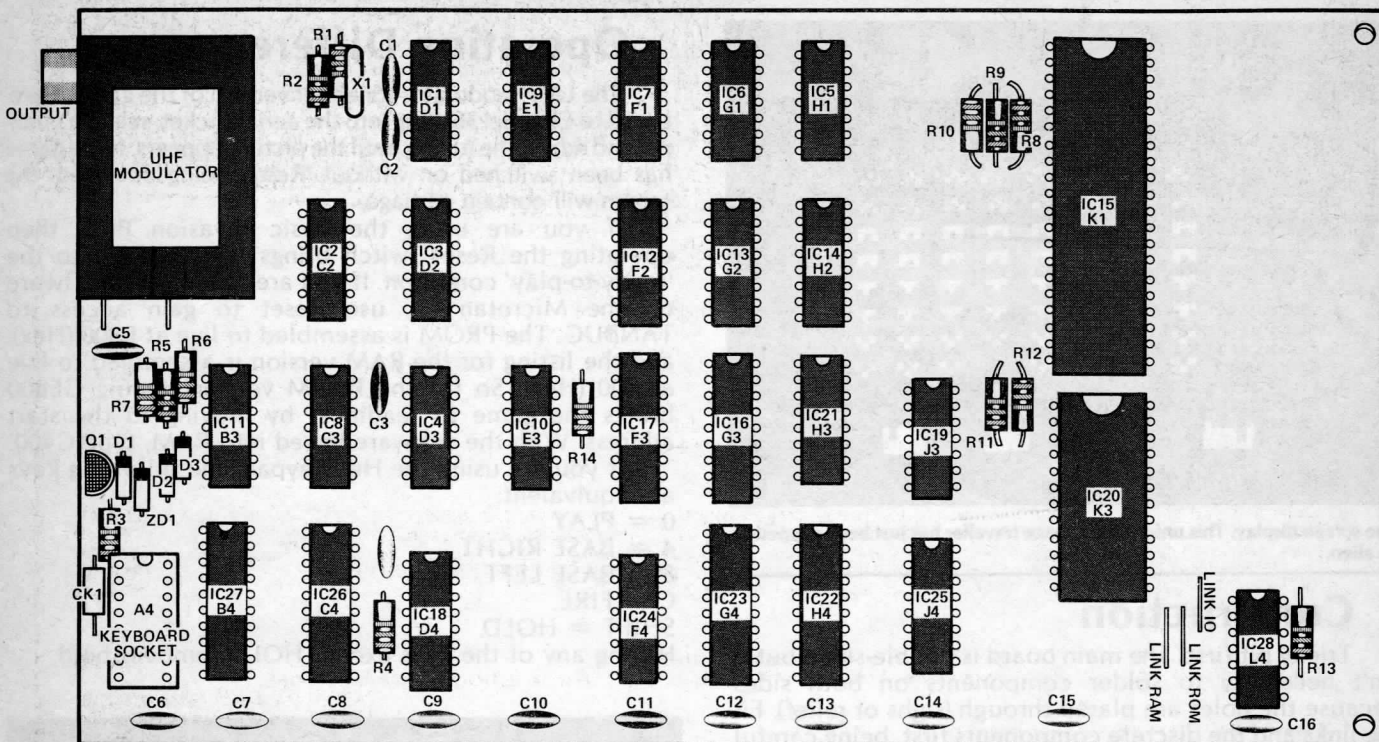

Fig.2. (above) Component overlay for the main board. All the chips face the same way.

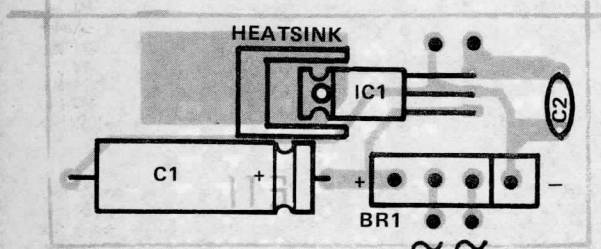

Fig.3. Component overlay of the power supply circuit. The heatsink is a type TV4, available from Watford Electronics.

## PARTS LIST

<b>Capacitors</b>	
C1	1000u 25 V electrolytic
C2	470n polycarbonate
<b>Semiconductors</b>	
IC1	7805
BR1	1.6 A 'In-Line' package
<b>Miscellaneous</b>	
T1	0.9 V @ 1 A
SW1	DPDT miniature toggle
heatsink	

## PARTS LIST

<b>Resistors all 1/4 W 5%</b>	
R1,2,4,8,9,10,11,12,13,14	1k0
R3	10k
R5	470R
R6	220R
R7	75R
<b>Capacitors</b>	
C1,4	10n ceramic
C2,3	100p ceramic
C5,6-16	47n disc ceramic
C6-16 are decoupling components, one for each column of ICs.	
<b>Semiconductors</b>	
IC1	74LS04
IC2	74LS73
IC3,4	74LS393
IC5	74LS21
IC6,11,28	74LS74
IC7	74LS08
IC8	74LS11
IC9	74LS86
IC10,19	74LS00
IC12,13,14	74LS157
IC15	6502
IC16,17	2114
IC18	DM8678BWF
IC20	2716
IC21	2102
IC22,23,26	74LS374
IC24	74LS251
IC25	74LS138
IC27	74LS244
Q1	BC184
ZD1	6V8 400 mW
D1-3	1N4148
<b>Miscellaneous</b>	
CH1	100 uH choke
X1	6 MHz crystal
UHF modulator	UM1111E36
PCB, case, 14-pin DIL socket (x13), 16-pin DIL socket (x8), 18 pin DIL socket (x2), 20 pin DIL socket (x4), 24 pin DIL socket, 40 pin DIL socket.	

Next month, we conclude the ETI Space Invasion Game with constructional details of the sound effects board.

ETI





## Piece Work

With the two latest additions to the successful Chess Challenger series of games, the Challenger is moving away from the concept of a chess board with a computer tacked onto the side, towards the truly electronic board. If you're wary of computers and keyboards, you may have been put off buying a chess machine up to now because of the business of entering your move on the keypad. The Sensory 8 gets round

that by featuring a touch-sensitive playing surface, by means of which the computer can 'see' the pieces and automatically enter each move. A light on each square shows the 'from' and 'to' positions. Eight levels of play can be selected and skill level can even be changed in mid-move. All the usual Chess Challenger features (position verification, problem-solving, etc.) are featured.

Following on from the Voice Chess Challenger, you can now also buy a Voice Sensory Chess

Challenger. In addition to all the Sensory 8's features, it speaks its own moves, repeats yours, calls out captures and rattles off all the board positions on command. If this dedicated dalek's voice gets a bit too much you can switch it off (unlike human opponents).

The voice version also has a built-in chess clock showing the time left for you or the computer and the elapsed time for the game. You can buy a plug-in printer to provide a copy of every move in the game. Sensory 8 sells for £129.95 and Voice Sensory for

£279.95.

Aimed at chess players with itchy feet, Ingersoll Electronics have introduced the Chess Traveller, featuring eight levels of play. The pieces push into holes on the board (with spare holes for taken pieces) and can be covered by a perspex top at half time or between games. Through the keyboard you can select skill level, verify board positions, solve problems and set up specific openings. Power is from mains or batteries. Chess Traveller retails at around £50.

## Oops

### Space Invasion Game

In the Space Invasion Game main circuit diagram (November 1980, p.66/67) pin 12 of IC11b is shown connected to earth. It should be connected to pin 34 of the CPU, IC15. All new boards supplied by Tangerine Computers will have this modification, so check your board before making any changes.

On the same diagram, the ICs are identified in two ways. Our own IC1, IC2, etc. notation identifies the components as they appear on the Parts List. The circled legends (A1, A2, B1, H4, etc.) are the positions of the ICs shown on the PCB supplied by Tangerine Computers.

IC20 pins 20 and 21 should be swapped over. The label adjacent to IC7c was ringed in error — it is diode D2 not position D2.

## Cassette Interface

In the component overlay of the Cassette Interface project (October 1980 p.65 Fig.5) the junction of R4-R5-R6-C4 is shown connected to pin 1 of IC6. Instead it should be connected to pin 2 of IC6. The circuit diagram is correct but the foil pattern on p.109 is incorrect. Simply break the track connecting the above components to pin 1 and solder a new link across to pin 2. The Buylines information omitted from this project was included in Digest in the November issue.

## Radio Control

In the Radio Control Buylines section (October 1980) the prices quoted for the transmitter and receiver do not include PCBs, receiver case or SLM three-pin gold-plated servo connector block. Prices including these items are £8.57 for the transmitter kit and £14.26 for the receiver kit (including VAT) from Ambit International.

## The Inch War

Length may not be everything, but JVC want to know how important it is to video tape recorder owners. They are shortly to test market four hour VHS tapes in the UK. As it is a test exercise, the new E240 tapes will be in very short supply until the experiment is complete and demand is established.

JVC expect the demand to come from owners of their new HR7700 recorder, with which every absentee landlord worth his salt can tape up to eight programmes from different channels in a fortnight.

So, if you like the idea of four hour VHS tapes, seek out the elusive JVC test retail outlets and form an orderly queue with piggy banks at the ready.

# HELP! ETI NEEDS YOU!

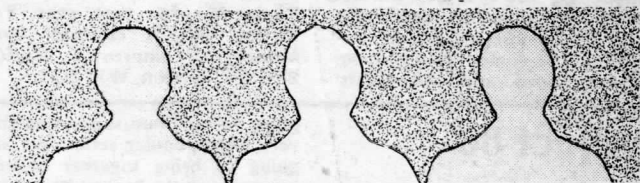

Could you be a Project Engineer for ETI? — the person who fills this position will be able to design and build up projects to the standard of finish ETI readers are used to seeing in their magazine. This calls for someone with a good knowledge of circuit design and with the patience to carry the design through to a finished state. Existing staff are available to assist in all aspects of design work. The easiest part of the job will be writing up the project once it is completed. None of the present ETI technical staff were journalists previous to joining, and no-one has found the writing a difficult task.

We have no preconceived notions of age required.

Applications should reach us as soon as possible with C.V.

Apply in writing to:  
The Editor,  
Electronics Today International  
145 Charing Cross Road,  
London WC2H 0EE

# SPACE INVASION SOUND EFFECTS

Your first space invasion is but a moment away. We conclude our Invasion Game project with constructional details of the control and sound effects board. Design and development by Steve Ramsahadeo.

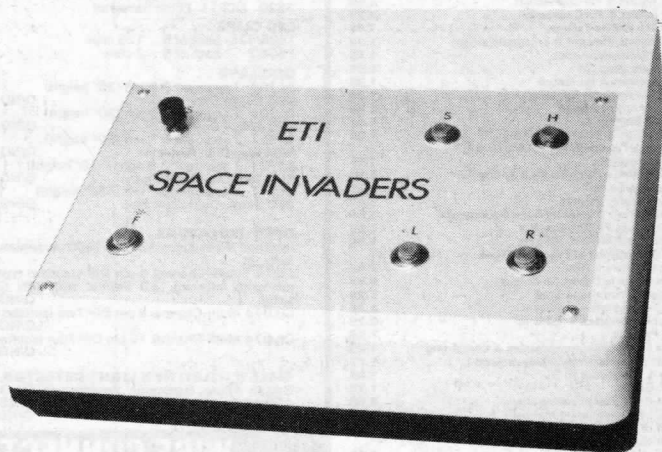

Last month we dealt with the main board and power supply, but before you can start repelling invaders you need a handful of controls. Our control board incorporates a sound effects generator — a must for this game.

There are four sounds in all — heartbeat, fire, saucer and explosion. The explosion is not produced by the sound board. It's taken care of by the software. When you press the start button (S on the front panel) the aliens start to advance across and

Fig.1. Circuit diagram of the control board.

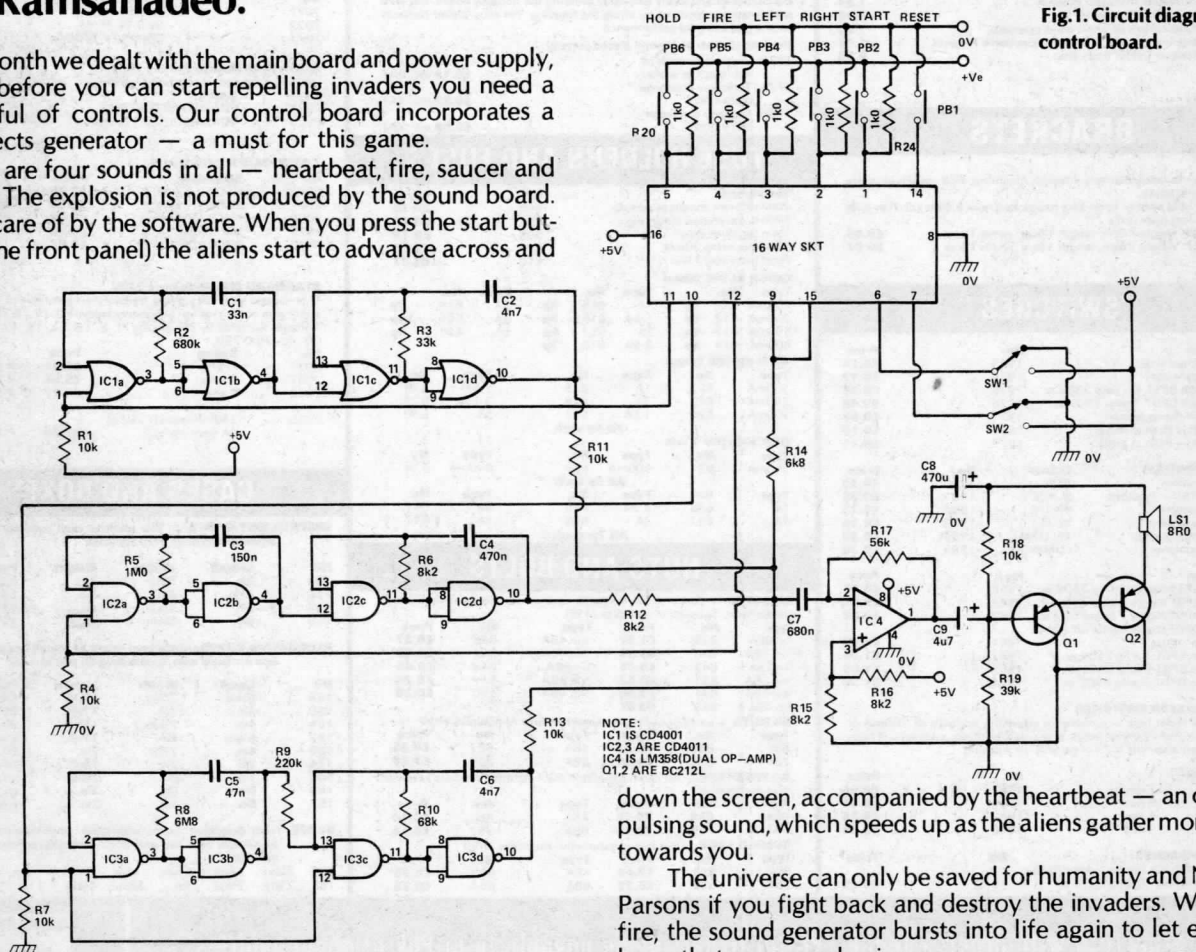

down the screen, accompanied by the heartbeat — an ominous pulsing sound, which speeds up as the aliens gather momentum towards you.

The universe can only be saved for humanity and Nicholas Parsons if you fight back and destroy the invaders. When you fire, the sound generator bursts into life again to let everyone know that you mean business.



## BUYLINES

Tangerine Computers Ltd can supply the ET1 Space Invasion project built for £99.85 all inclusive (£80.85 in kit form). The sound generator and keypad section is available built for £20.25 all inclusive (or £15.38 in kit form).

If you want to shop around for your own components, you can get the main PCB for £21.15 and the sound generator board for £5.60. The ROM is available for £17.75. Prices are all inclusive. Tangerine Computers Ltd, Forehill, Ely, Cambridgeshire.

We built the project in a new plastic desk-top, sloping front case from Vero measuring 228x216x76mm (industrial order code 65-5033K).

Vero Electronics Ltd, Industrial Estate, Chandler's Ford, Hampshire SO53ZR.

## HOW IT WORKS

Logic instructions are transferred to and from the main board via a 16 way socket. Instructions go to IC27 on the main board via pins 1-7 and 14 and return from IC26, main board via pins 9, 10, 11, 12. For example, when the fire button (PB5) is pressed, the main board detects this and gates pin 1 of IC1a low (logic 0) via pin 11 of the socket. IC1 is wired as a dual gated NOR astable and generates a pulsed tone signal to give the 'fire' sound.

IC2 and IC3 generate the heartbeat and saucer sounds in a similar way except that these are gated on by a high (logic 1) at the respective socket pins (12 and 10), and so NAND astables are required.

The hit sound is programmed into the software and is made available at pin 9 of the 16 way socket.

IC4 acts as a summing amplifier, combining at pin 2 the outputs of the three oscillators and the hit sound (via C7). R11-14 and R17 determine the relative gain of each of the sounds. The output of IC4 is then amplified by transistors Q1 and Q2.

## PARTS LIST

## Resistors all ¼ W 5%

R1,4,7,11,13,18	10k
R2	680k
R3	33k
R6,12,15,16	8k2
R8	6M8
R9	220k
R10	68k
R14	6k8
R17	56k
R19	39k
R20 - 24	1k0

## Capacitors

C1	33n polycarbonate
C2, 6	4n7 polycarbonate
C3	150n polycarbonate
C4	470n polycarbonate
C5	47n polycarbonate
C7	680n polycarbonate
C8	470u 25 V electrolytic
C9	4u7 16 V tantalum

## Semiconductors

IC1	CD4001
IC2,3	CD4011
IC4	LM358
Q1,2	BC212L

## Miscellaneous

SW1,2	SPDT miniature toggle
PB1-6	momentary push buttons
LS1	2" diameter speaker
2 off 16 way DIL IDC (Insulation Displacement Connector)	
PCB	
Vero case	

You can gamble on boosting your score to an all-time record by ignoring the aliens for the moment and firing at a flying saucer, which zooms across the top of the screen every now and then. The appearance of the saucer is heralded by its very own unmistakable sonic trademark (in other words — the racket it makes is different from the others). Keep banging away at the aliens or divert your attack to the flying saucer? It's your decision.

## Construction

The unit is assembled on one PCB with a separate power supply. Construction is straightforward provided that care is taken and attention paid to the orientation of all polarised components.

Begin by inserting all wire links and Veropins followed by the IC sockets, resistors, diodes, capacitors and transistors. The ICs should be inserted last, after all the wiring to the hardware components has been completed.

The PCB fits neatly in the top left-hand corner of the specified Verocase as shown in the accompanying photographs.

A 200 mm length of 16 way Speedbloc ribbon cable using DIL (dual-in-line) connectors at each end will have to be made up. This cable will link the main board and sound board, completing the logic and power supply connections.

The pushbuttons (PB1-6) and difficulty switches (SW1,2, mounted at the rear of the case along with the mains switch) can now be wired up.

Finally, the loudspeaker is mounted at the top of the case, a few drops of Super-glue being enough to fix it firmly into place. After checking all is well, prepare for battle!

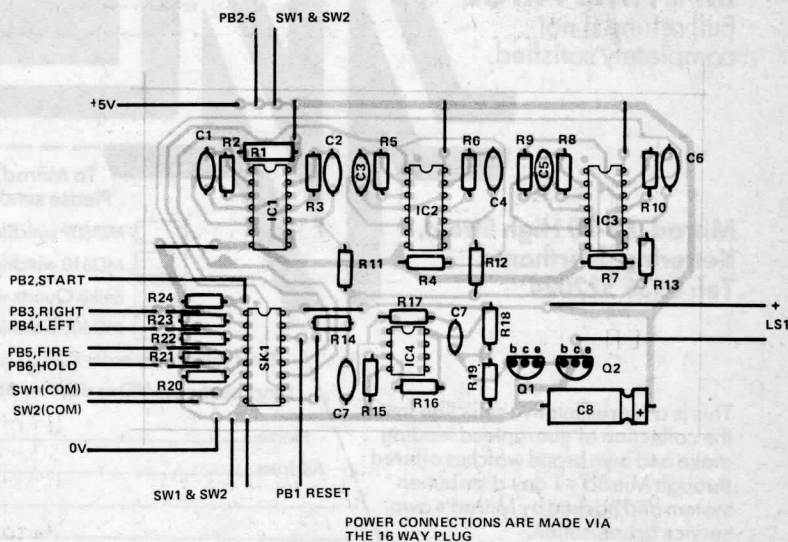
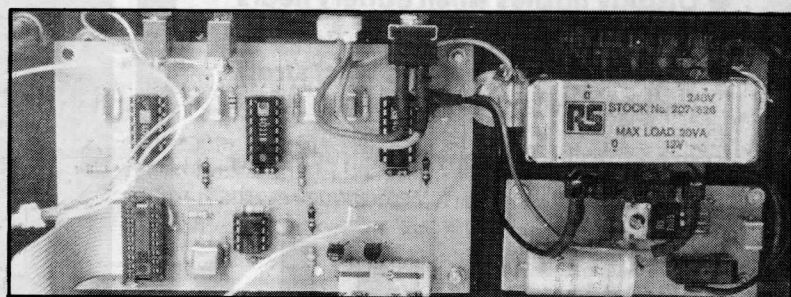

Fig.2. Component overlay.

ETI



# SPACE INVASION MODIFICATIONS

Space Invasion grows up! Here are the changes to convert it into your very own personal computer.

**B**ack in the November '80 ETI we featured the Space Invasion TV game from Tangerine Computers. The design as published was effectively a microcomputer dedicated to a single task — running the Space Invasion program. With the simple additions and alterations given here, the project becomes a fully-fledged personal computer, equivalent to the Microtan 65 and able to use all of the expansion boards in the Tangerine range.

Before discussing the modifications, we ought to mention a few alterations to the original circuit. Pin 12 of IC11b is shown connected to earth. It should be connected to IC15 pin 34. All new boards being supplied by Tangerine have this modification to the track pattern, so check your board before making any changes. IC20 pins 20 and 21 should be swapped over, and the label adjacent to IC7c was ringed in error — it is diode D2, not IC position D2. The unmarked pin on IC9c is pin 11.

## All Change

There are only a handful of extra components required to complete the conversion. An additional character generator enables the screen to display the lower case alphabet. Connection to other boards in the Tangerine system is made via the multiway socket that comes ready-soldered to the PCB — the bus signals need a high driving capability and the tri-state buffers for the address bus are located on the CPU card. (Buffers for the data bus are on the TANEX card.) If you feel content with only 1K of RAM and machine code programming, the address buffers won't be necessary. The remaining components provide various timing and control signals.

## Soft Option

Even with these changes, the board will still only play Space Invasion unless you change the software. This is simple — remove the EPROM (IC20), return it to the protective foam from whence it came, and replace it with either the 1K TANBUG ROM or the 2K XBUG ROM, from Tangerine. The former is OK if you are happy with the limitations of the basic board, but if you plan to expand at some later date into a larger system with more I/O, the extra facilities of XBUG make it a better buy.

If you don't already have the Hex keypad or ASCII keyboard, you'll need one or the other to allow you to enter your own programs.

## Spreading Out

The first step in expanding the system is to purchase the TANEX card. This is connected to the CPU card by plugging both boards into a motherboard, and provides a cassette interface, 16 I/O lines, two 16 bit counter timers, the aforementioned data bus buffers and an additional 1K of RAM. This board also takes over the address decoding of the memory map for the

system, which is incompatible with the simpler, hardwired memory map of the CPU card. If TANEX is to be used, it is necessary to cut the three wire links on the CPU card (LINK RAM, LINK ROM and LINK I/O).

Plugging extra chips into the TANEX board will give you up to 8K of RAM, 16 more I/O lines, two more counter timers, serial I/O and 10K BASIC in ROM. Once you've got the BASIC you'll need an ASCII keyboard, and when you start writing huge programs, TANRAM will come in handy (up to 40K of extra memory).

And what if, after all this, you still feel a yearning to play Space Invasion again? No problem — either swap the ROM chips back again if you only have the CPU card, or insert the Invasion ROM in position E2 on TANEX and proceed as instructed in the original article.

Prices for the unusual chips are as follows; the TANBUG ROM (ask Tangerine for TANBUG1, issue 2 board) costs £20.05 including VAT and postage, XBUG is £20.25, and the DM8678CAE is £8. All these prices include VAT and postage. For details of the other boards in the Tangerine range, get in touch with them at Forehill Works, Forehill, Ely, Cambs.

## HOW IT WORKS

The basic Space Invasion unit requires only a few small modifications to the hardware and software to become a useful personal computer. The software is easily dealt with — by removing the ROM chip, IC20, and inserting a TANBUG ROM in this socket, we replace the fixed games program with a general purpose monitor.

The existing circuit already has upper case alphanumerics and graphics options; IC32 is a character generator for lower case alphabet.

If the system is to be expanded by connecting additional boards in the Tangerine range, then tri-state buffers are required. IC33, 34, 35 take care of this, receiving their control signal from the TANEX expansion board.

The remaining components provide additional decoupling and timing signals which are required by the complete system.

## PARTS LIST

### Resistors (all ¼ W, 5%)

R15,17 10k  
R16 1k0

### Capacitors

C17 1n0  
C18 47n

### Semiconductors

IC20 TANBUG ROM (or XBUG)  
IC29,30,31 74LS74  
IC32 DM8678CAE  
IC33,34,35 74LS367  
Q2,3 BC184



- Kits for Signal Generators - Digital Meters etc.
- Semi-conductor technology.
- Examination courses (City & Guilds etc.) in electronics.
- Radio Amateurs Licence. ● Logic/Digital techniques.

# MASTER THE REST

- Services of skilled tutor available.
- Computer supplied ready for use. ● Self Test program exercise.
- Complete Home Study library. ● Special educational Mini-TECH WORK - THEIR 'LANGUAGE' AND HOW TO DO PROGRAMS.

# MASTER COMPUTERS

- Learning HOW TO REALLY UNDERSTAND COMPUTERS, HOW TO DO PROGRAMS.
- Building an oscilloscope. ● Recognition of components.
- Understanding circuit diagrams. ● Handling all types Solid State 'Chips'.
- Carry out over 40 experiments on basic circuits and on digital electronics.
- Testing and servicing of Radio, T.V., Hi-Fi and all types of modern computerised equipment.

# MASTER ELECTRONICS

BY SEEING AND DOING  
LEARN THE PRACTICAL WAY

Learn the technology of the future today in your own home. can attain, through us, in simple, easy to understand stages. Knowledge of its operation and its use is vital. Knowledge you will revolutionise every human activity over the next ten years. Be it a career, hobby or interest, like it or not the Silicon Chip

# Conquer the chip.



**ETI**  
Please send your FREE brochure without obligation to:

Name \_\_\_\_\_  
Address \_\_\_\_\_  
(Block Caps please)

ET/7/813  
BRITISH NATIONAL RADIO & ELECTRONICS SCHOOL,  
4 CLEVELAND ROAD, JERSEY, CHANNEL ISLANDS.

I am interested in  
PRACTICAL ELECTRONICS  
COMPUTER TECHNOLOGY  
OTHER SUBJECTS (please state \_\_\_\_\_)  
your interests) \_\_\_\_\_

Fig. 1 The additional components are shown in black on the original (fainter) overlay. Tangentine use letter/number combinations to identify the IC sockets and these are indicated on each IC.

